

Options (unit: mm)

Finger Guards

Model : 109-139E Surface treatment : Nickel-chrome plating (silver)
 : 109-139H : Cation electropainting (black)

Color

Resin Finger Guards

Model : 109-1003G

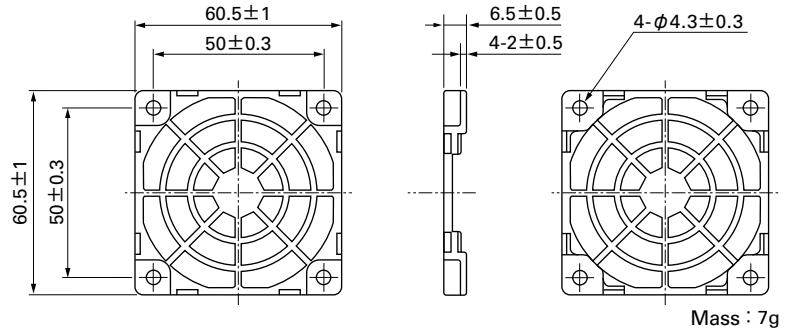
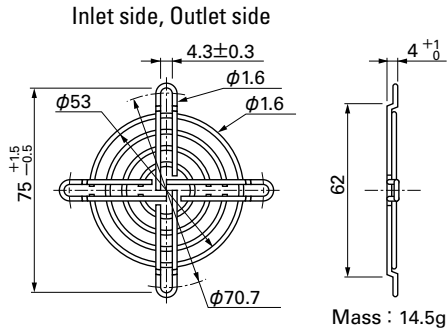

Airflow - Static Pressure Characteristics

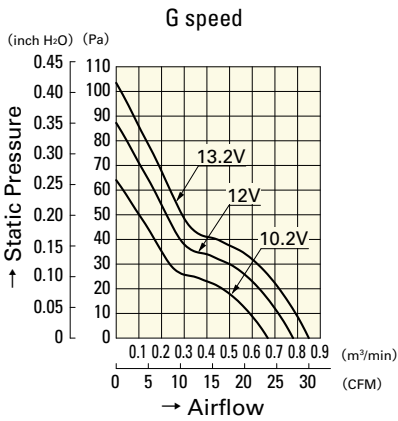

9WP0612G401

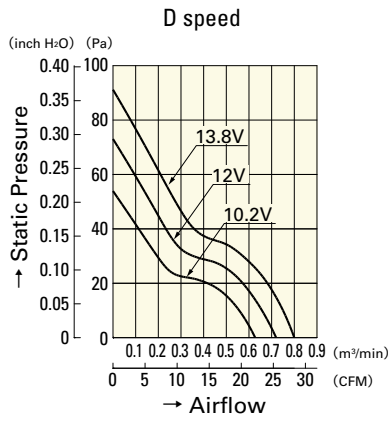

9WP0612D401

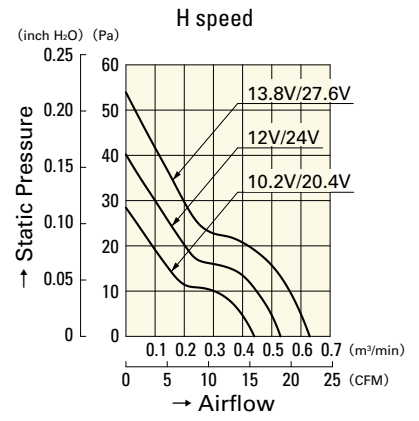

9WP0612H401
9WP0624H401

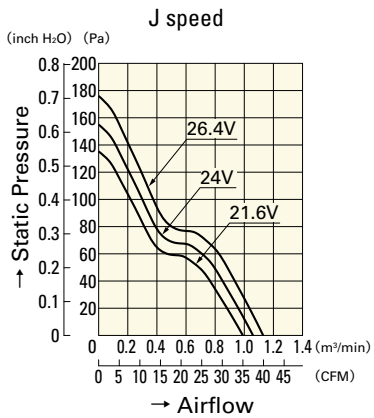

9WP0624J401

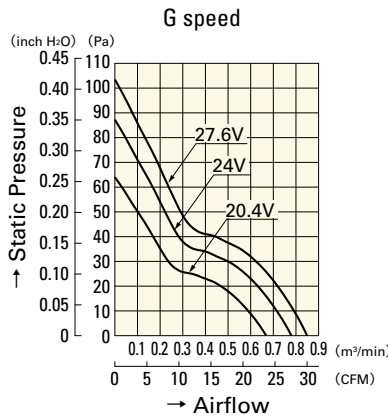

9WP0624G401

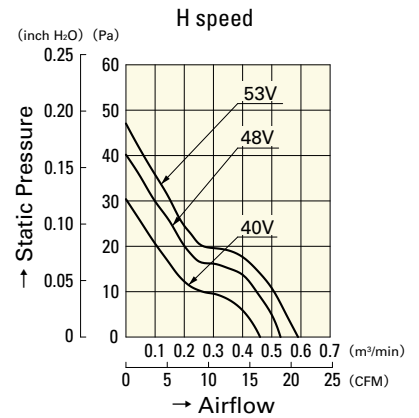

9WP0648H401