

Reference Dimensions of Mounting Holes and Vent Opening (unit: mm)

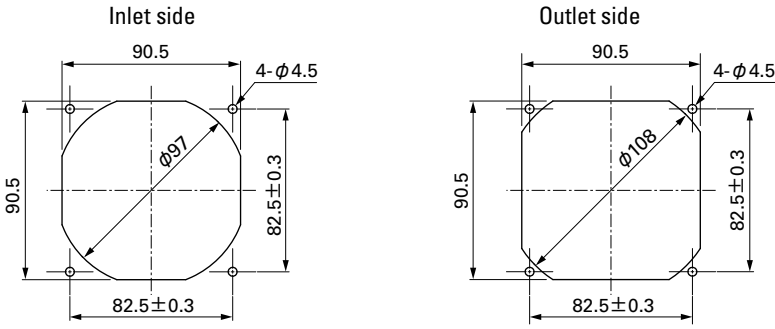

Options (unit: mm)

Finger Guards

Model : 109-099C Surface treatment : Nickel-chrome plating (silver) Color

Model : 109-099E Surface treatment : Nickel-chrome plating (silver) Color
: 109-099H : Cation electropainting (black)

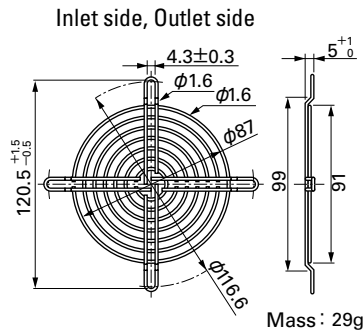
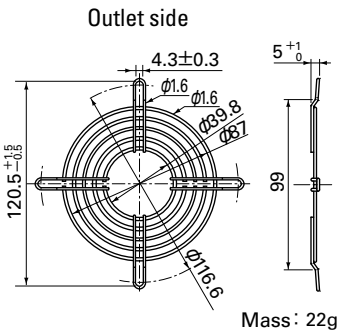

Resin Finger Guards

Model : 109-1001G

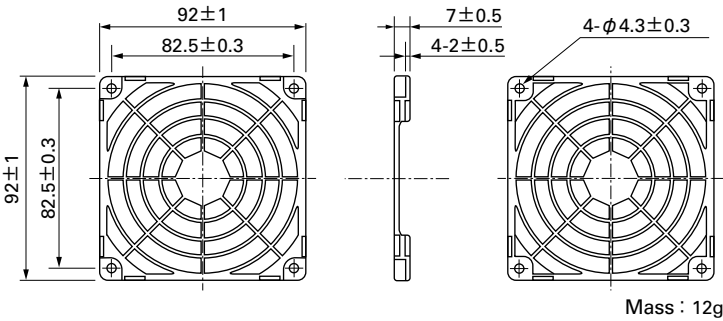

Airflow - Static Pressure Characteristics

PWM Duty Cycle

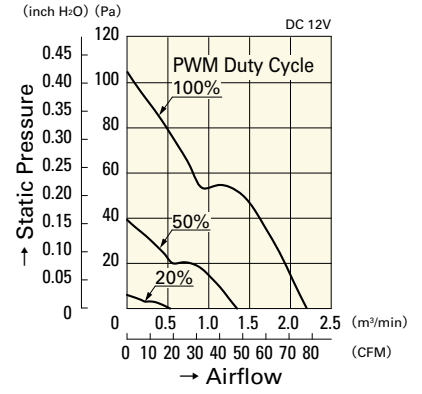

9WL0912P4J001

Operating Voltage Range

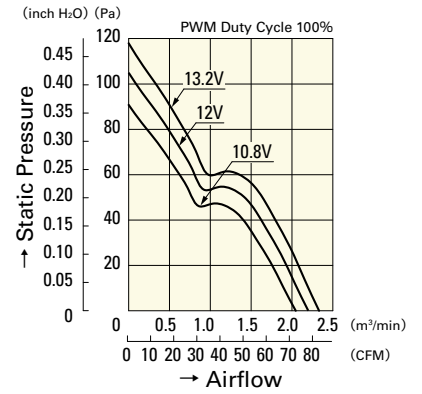

9WL0912P4J001

PWM Duty - Speed Characteristics Example

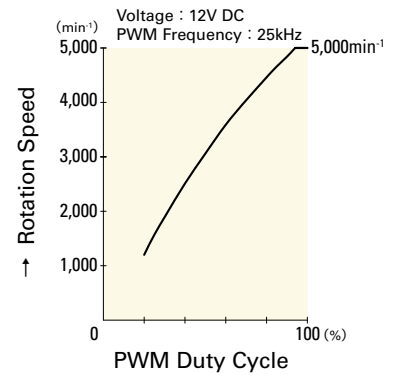

9WL0912P4J001

92mm sq.

San Ace 92W

92×92×25mm [Mass : 170g]

Airflow - Static Pressure Characteristics

PWM Duty Cycle

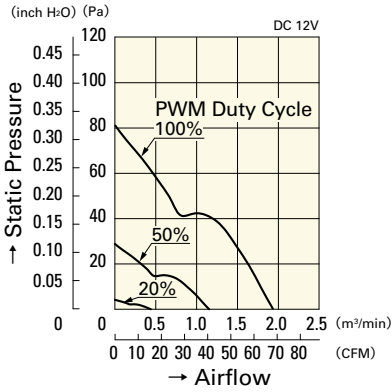

9WL0912P4G001

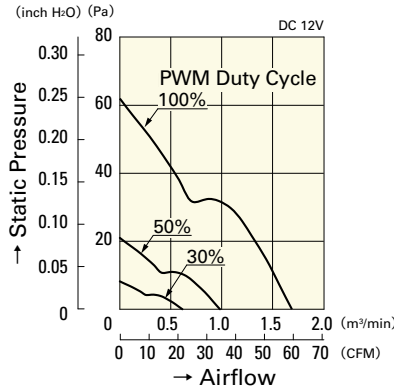

9WL0912P4S001

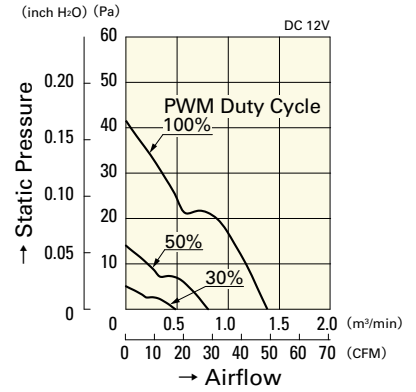

9WL0912P4H001

Operating Voltage Range

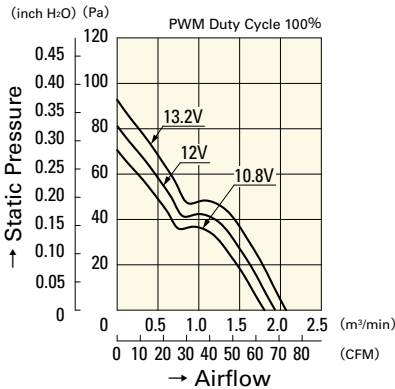

9WL0912P4G001

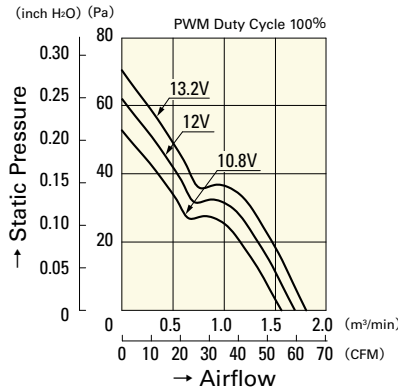

9WL0912P4S001

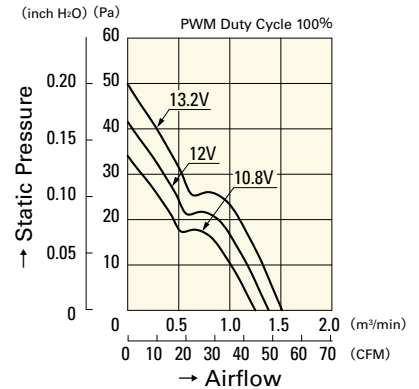

9WL0912P4H001

PWM Duty - Speed Characteristics Example

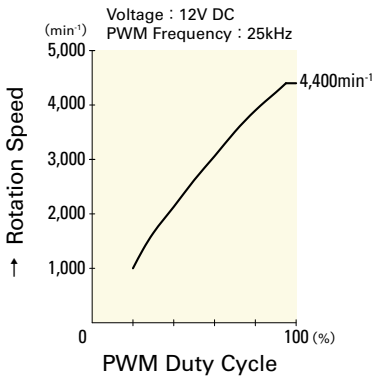

9WL0912P4G001

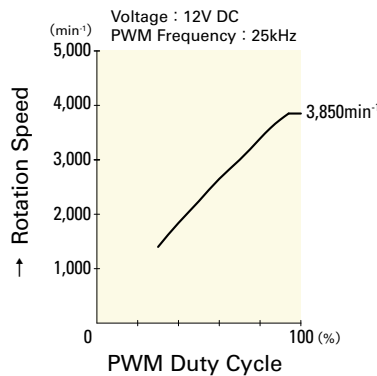

9WL0912P4S001

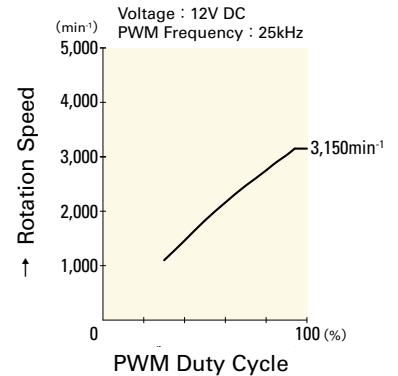

9WL0912P4H001

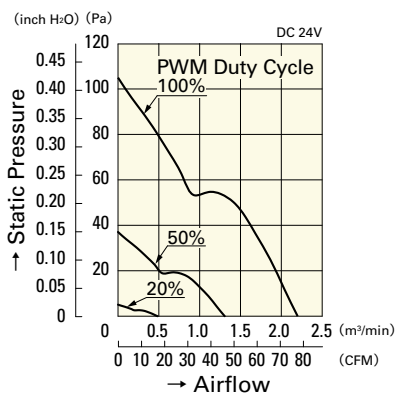

9WL0924P4J001

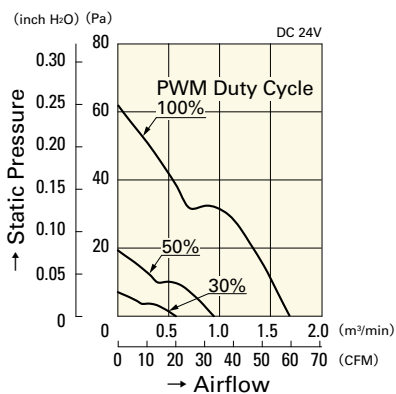

9WL0924P4S001

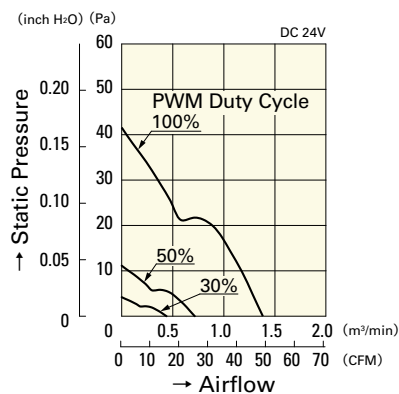

9WL0924P4H001

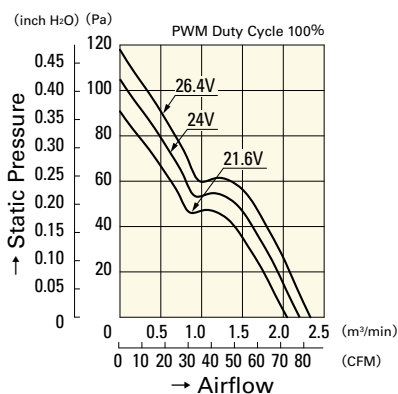

9WL0924P4J001

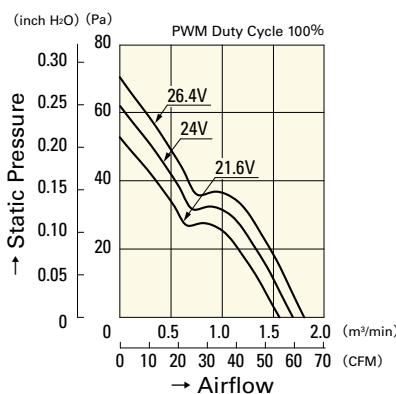

9WL0924P4S001

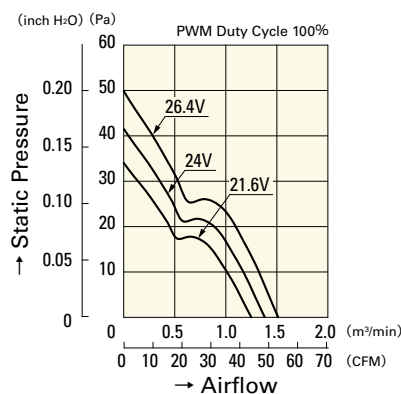

9WL0924P4H001

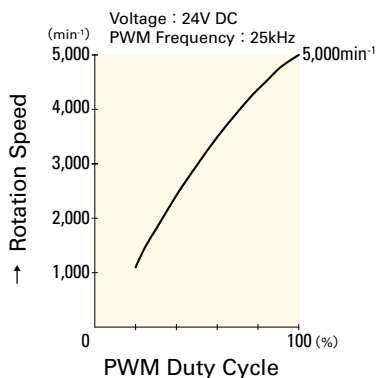

9WL0924P4J001

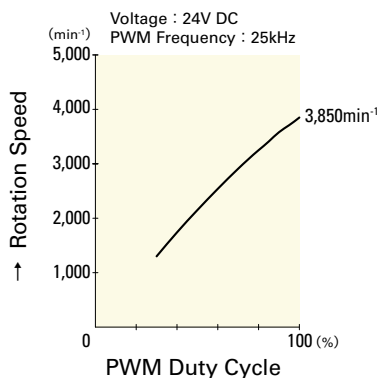

9WL0924P4S001

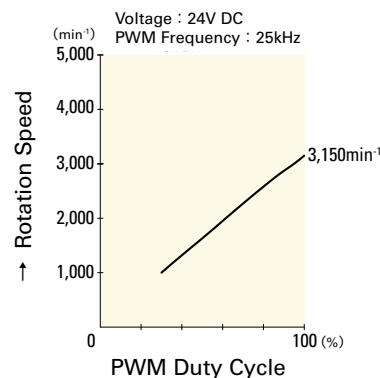

9WL0924P4H001