

Options (unit: mm)

Finger Guards

Model : 109-319E Surface treatment : Nickel-chrome plating (silver) Color : 109-319H : Cation electropainting (black)

Model : 109-320 Surface treatment : Nickel-chrome plating Color (silver)

Finger guards 109-319E, 109-319H, and 109-320 should be mounted with two holes as in the drawing and do not use any other holes.

Inlet side, Outlet side

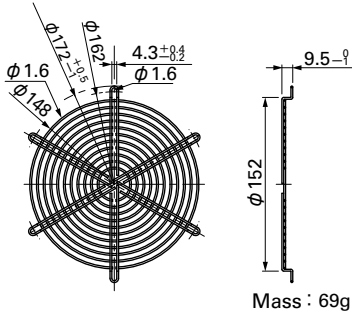

Outlet side

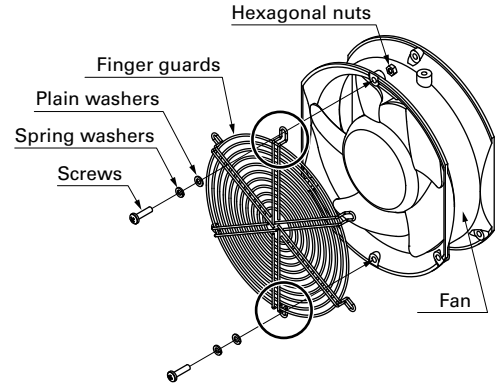
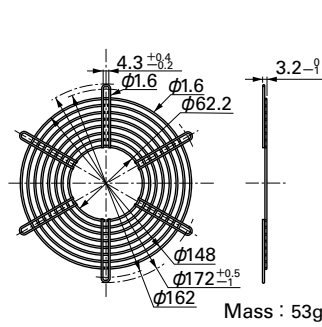

Airflow - Static Pressure Characteristics

PWM Duty Cycle

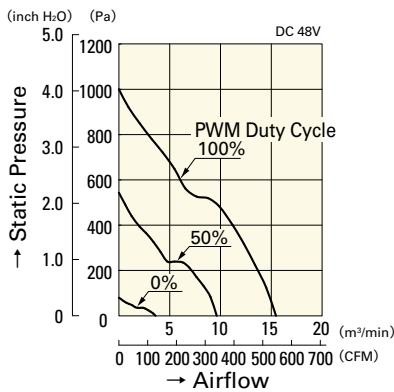

9WG5748P5G001

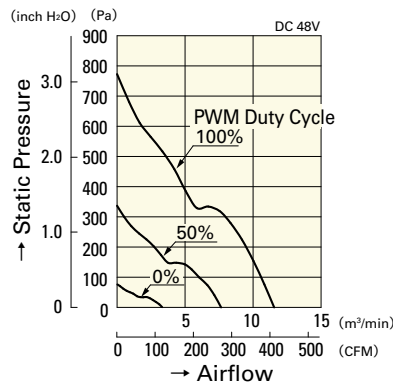

9WG5748P5H001

Operating Voltage Range

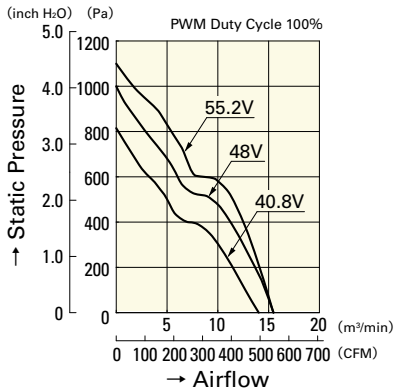

9WG5748P5G001

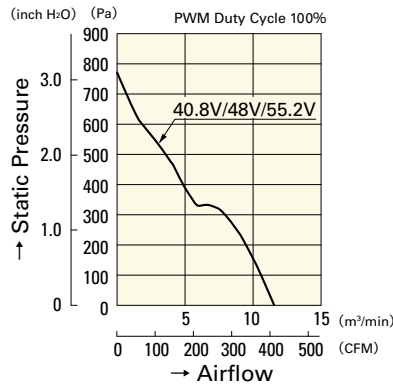

9WG5748P5H001

PWM Duty - Speed Characteristics Example

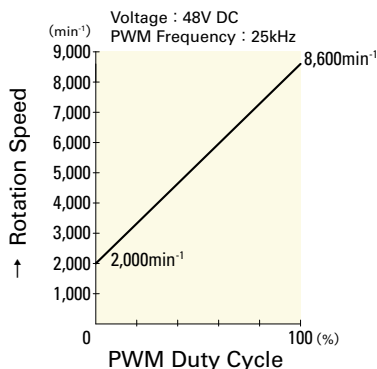

9WG5748P5G001

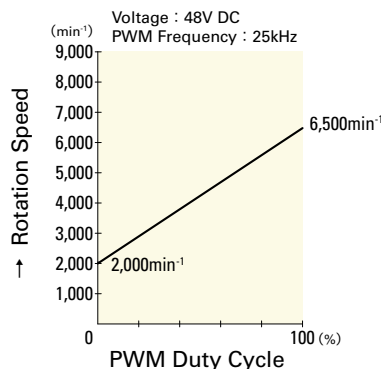

9WG5748P5H001