

Options (unit: mm)

Inlet Nozzle

Model: 109-1069 Material: Steel sheet Surface treatment: Electro nickel plating (silver)
 : 109-1069H : Steel sheet : Cation electropainting (black)

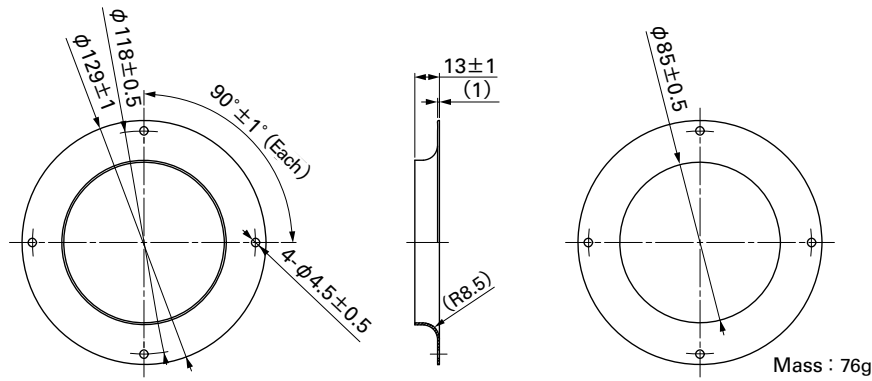

Finger Guards

Color
 Model: 109-1112 Surface treatment: Nickel-chrome plating (silver)

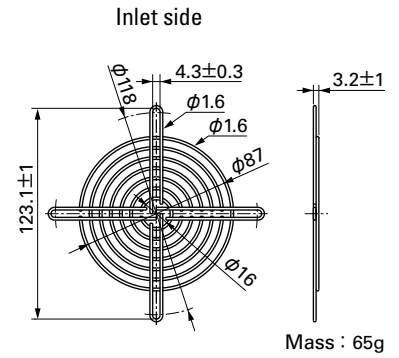

Inlet nozzle: Equipment to be mounted in inlet side for adjusting incoming airflow.

Reference Diagram for Mounting

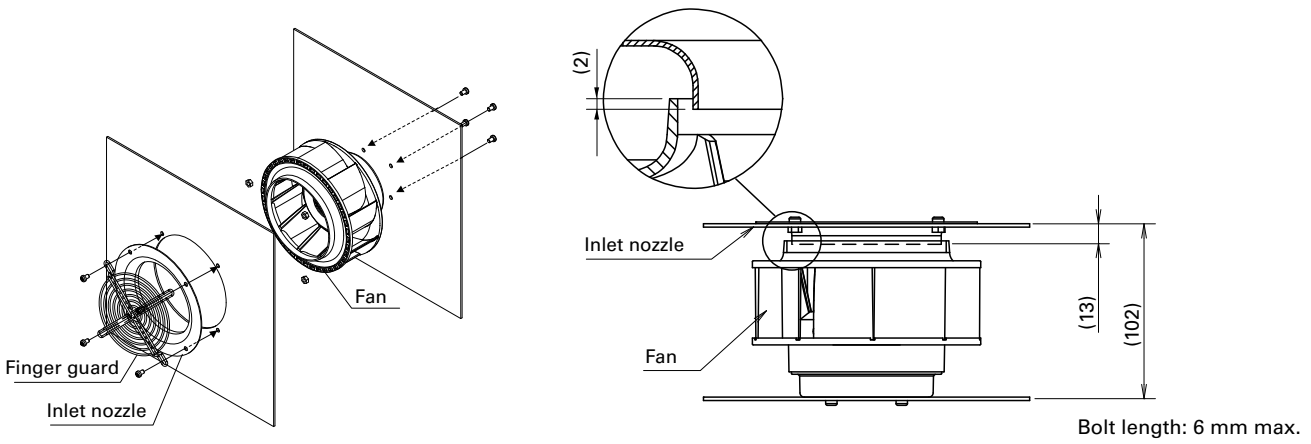

Airflow - Static Pressure Characteristics

PWM Duty Cycle

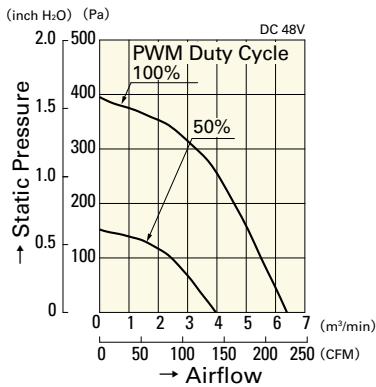

Operating Voltage Range

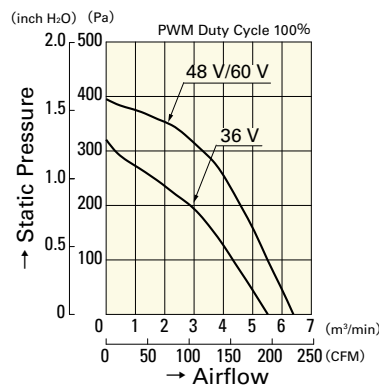

PWM Duty Speed Characteristics Example

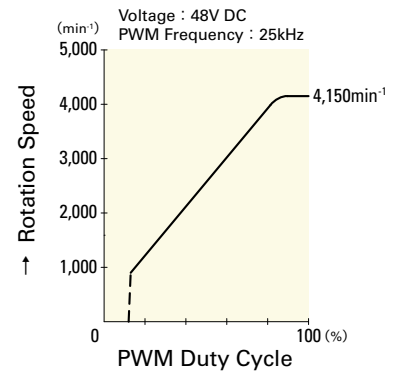

9W1TJ48P0H61

9W1TJ48P0H61

9W1TJ48P0H61

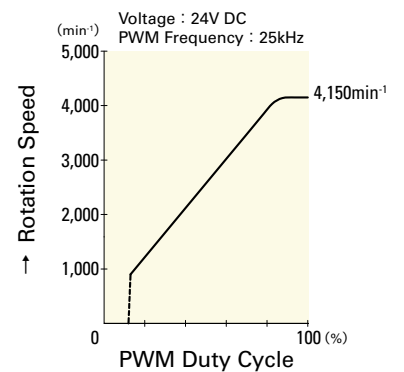
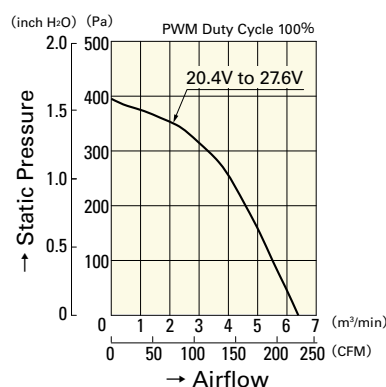
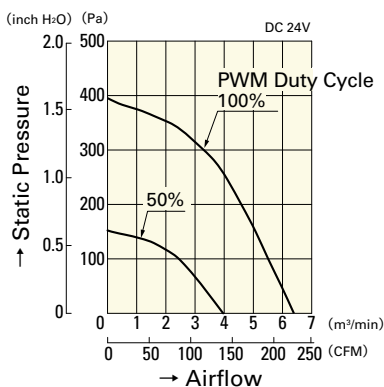

9W1TJ24P0H61

9W1TJ24P0H61

9W1TJ24P0H61

DC
 Splash Proof Centrifugal Fan 133mm