

Options (unit: mm)

Finger Guards

Model : 109-019C Surface treatment : Nickel-chrome plating (silver) Color : 109-019H : Cation electropainting (black)

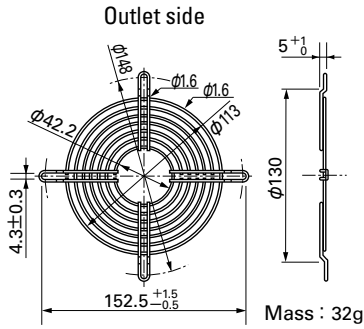

Resin Finger Guards

Model : 109-1000G

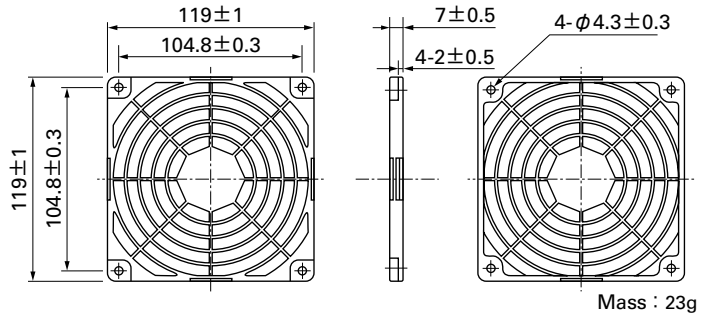

Model : 109-019E Surface treatment : Nickel-chrome plating (silver) Color : 109-019K : Cation electropainting (black)

Inlet side, Outlet side

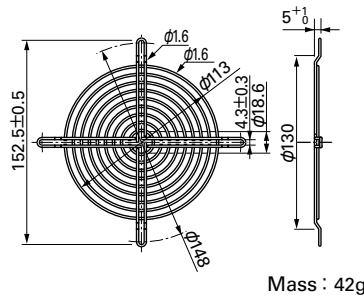

Airflow - Static Pressure Characteristics

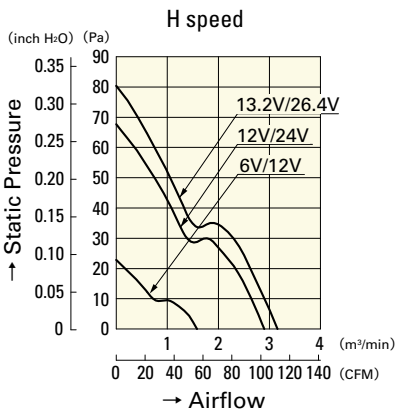

9WS1212H101
9WS1224H101

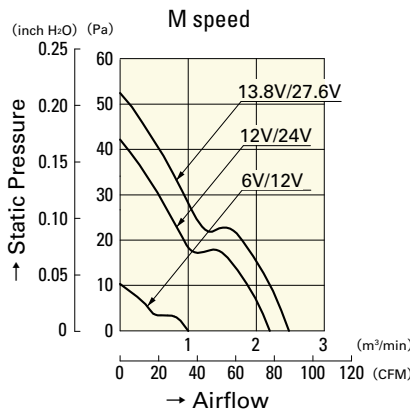

9WS1212M101
9WS1224M101

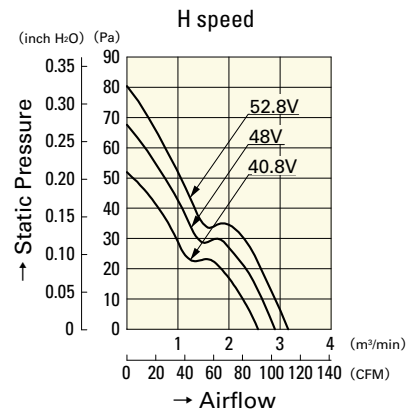

9WS1248H101

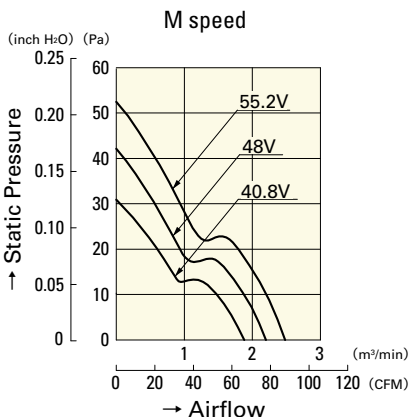

9WS1248M101